

Translation of prior care plan relationship diagram to new format

C-CDA R2.0, R2.1

Figure 25: Care Plan Relationship Diagram

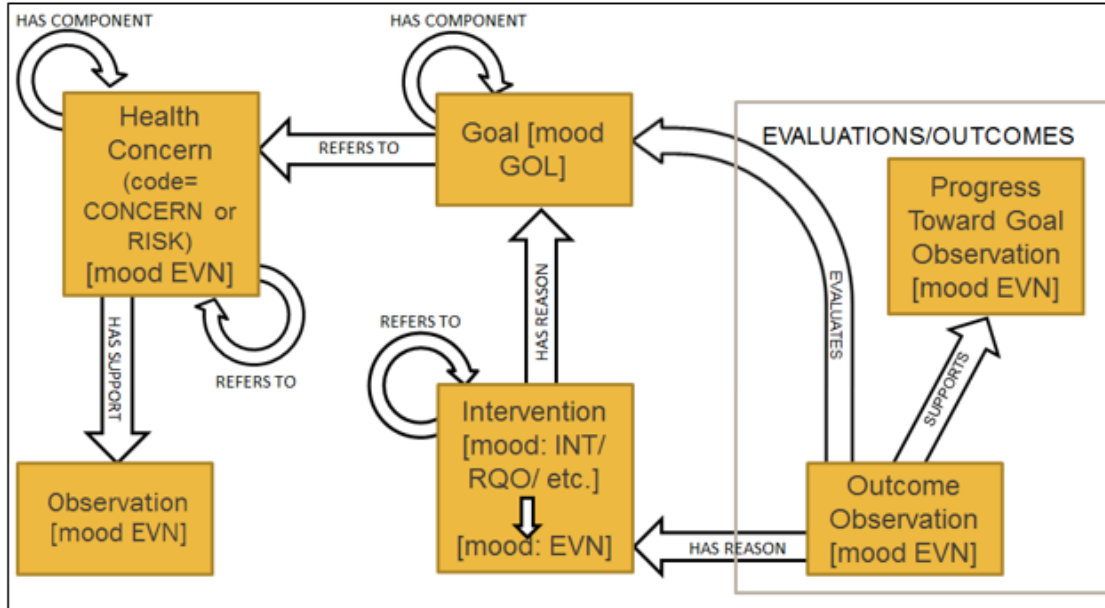

Care Plan

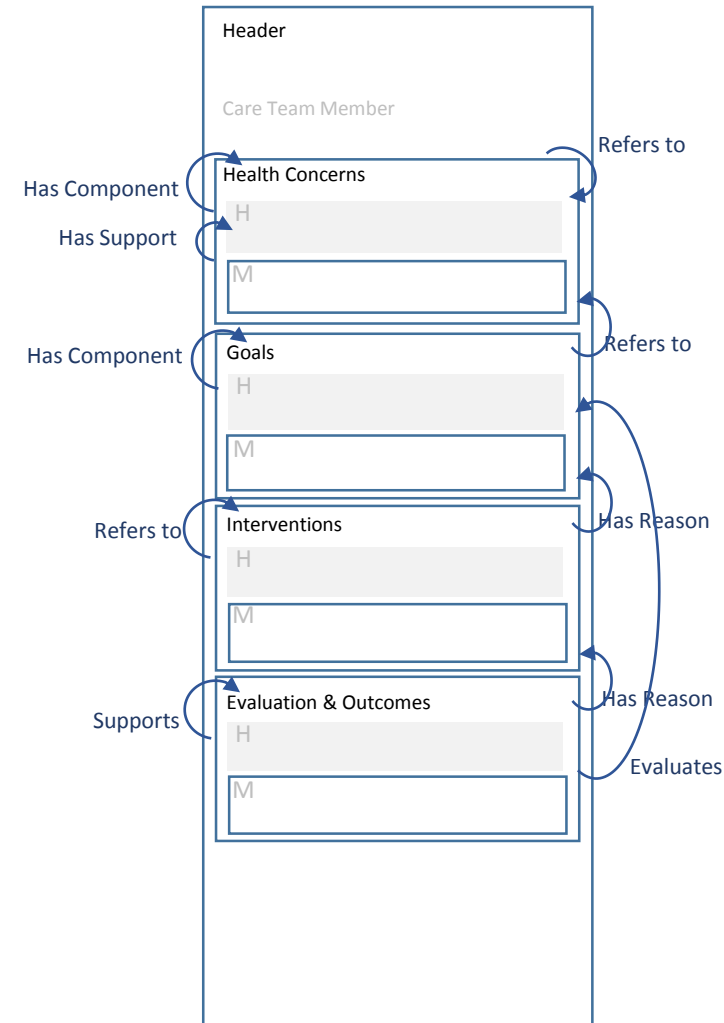

H = Human Readable Content
M = Machine Readable Entries

Personal advance care plan document relationship diagram to C-CDA Advance Directives Section

Clinical Summary*

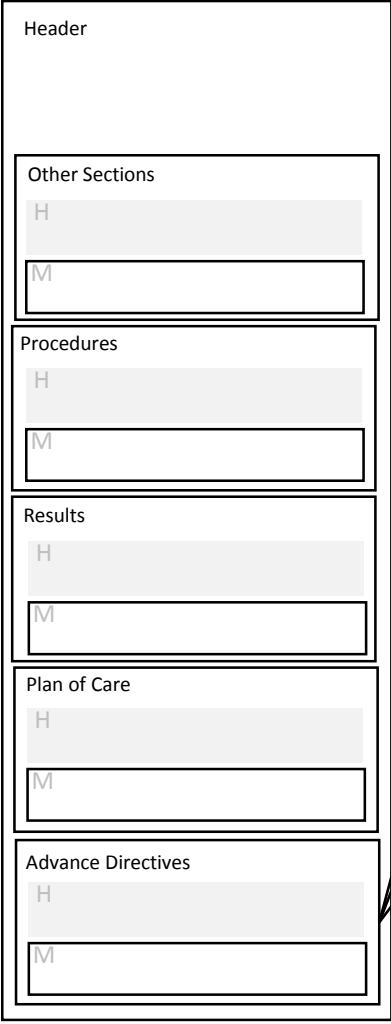

Personal Advance Care Plan Document



Care Plan

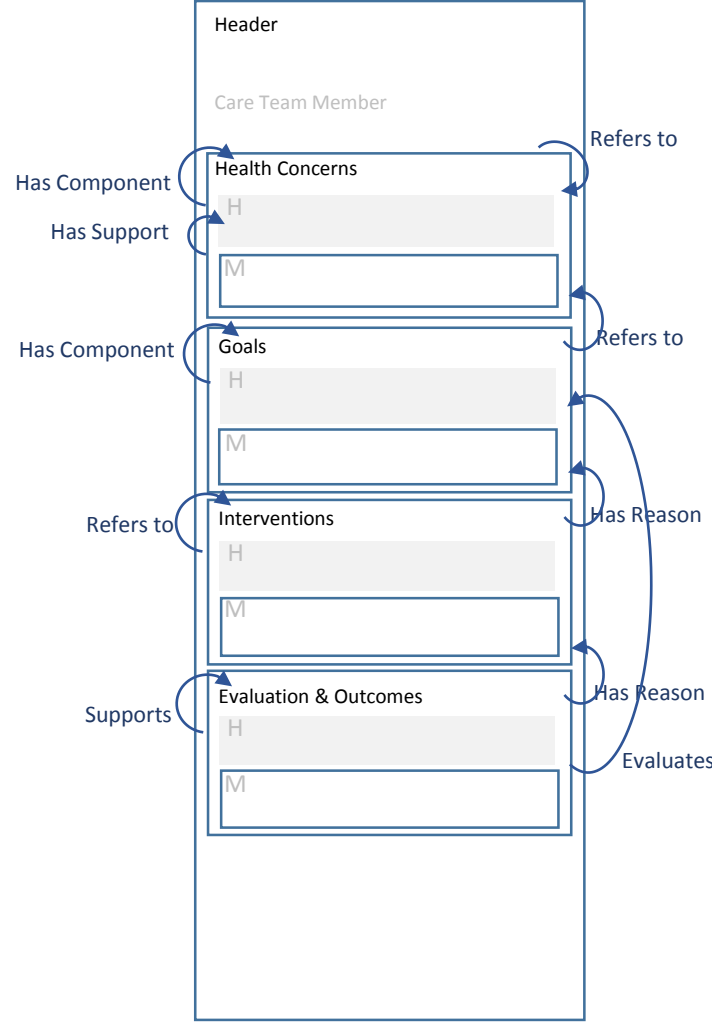

References

Informed by

Summarizes

* Continuity of Care Document, Consultation Note, Referral Summary, Transition of Care Document

GPP = Goals, Preferences, and Priorities

H = Human Readable Content
M = Machine Readable Content

"Future Potential" Personal advance care plan document relationship diagram

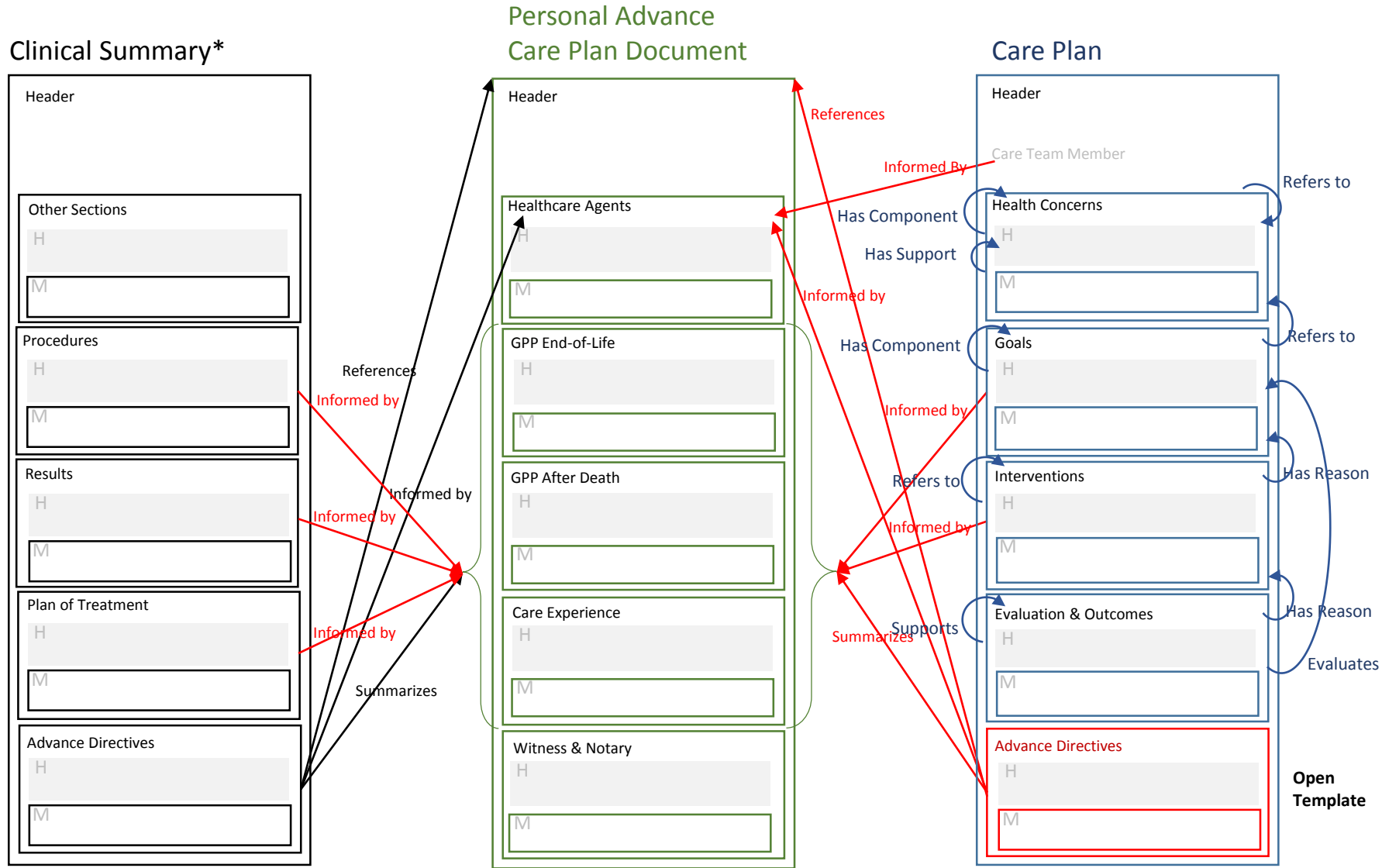

* Continuity of Care Document, Consultation Note, Referral Summary, Transition of Care Document

GPP = Goals, Preferences, and Priorities

H = Human Readable Content
M = Machine Readable Content